



reventon

INDUSTRIAL SOLUTIONS

Technical documentation

AIR WATER HEATERS IN EPP CASING HC-EC SERIES

MODELS:

HC 20-EC

HC 30-EC

HC 35-EC

HC 45-EC

HC 50-EC

HC 70-EC



EN

- 1. INTRODUCTION
 - 1.1 PRECAUTIONS
 - 1.2 TRANSPORT
 - 1.3 PACKAGE CONTENT
 - 1.4 USE
- 2. DEVICE CHARACTERISTICS
 - 2.1 CONSTRUCTION AND PRINCIPLE OF OPERATION
 - 2.2 DEVICE DIMENSIONS
 - 2.3 DEVICE TECHNICAL DATA
- 3. ASSEMBLY
 - 3.1 GENERAL PRINCIPLES
 - 3.2 ROTATING MOUNTING BRACKET
- 4. INSTALLATION INSTRUCTIONS
 - 4.1 CONNECTION OF THE DEVICE TO THE HYDAULIC SYSTEM
 - 4.2 CONNECTION OF THE DEIVCE TO THE ELECTRICAL SYSTEM
- 5. PRECAUTIONS & WARNINGS
- 6. CONTROLS
- 7. CONNECTION SCHEMES
 - 7.1 SCHEMES FOR HC20-EC, HC30-EC, HC35-EC, HC45-EC
 - 7.2 SCHEMES FOR HC50-EC, HC70-EC
- 8. TERMS OF WARRANTY

1. INTRODUCTION

Thank you very much for purchasing air water heater HC-EC. We would like to congratulate you on excellent choice. Please read and keep this manual.

1.1 PRECAUTIONS

The buyer and the user of the air water heater Reventon Group brand should read carefully the following instructions and proceed to the content recommendations. Proceeding due to the following instruction guarantees the correct usage and safety. In case of any doubts please contact directly Reventon Group sp. z o. o. [Ltd.]. The producer reserves the rights to make changes to the technical documentation without previous notice. Reventon Group sp. z o. o. [Ltd.] is not responsible for the damages which occur due to improper installation, not keeping the device in repair or using the device out of line. The installation should be carried out by the professional installers, who possess the qualifications to install these types of devices. The installers are responsible for making the installation as instructed in the technical data. In case of unserviceable please plug out the device and contact with the authorized for repair person or the supplier. During the installation, use, service and periodical inspections all regulations and safety rules must be followed.

1.2 TRANSPORT

During the acceptance of goods, it is needed to check the device to exclude any damages. During the transport, it is needed to use the proper equipment, it is necessary to carry the device by two people. In case of any damages please fill in the damage report in presence of the supplier.

1.3 PACKAGE CONTENT

- heater
- operation and maintenance manual and warranty card

1.4 USE

Heating devices Reventon Group HC series are used to heat spaces such as: production halls, warehouses, commercial room, service spaces, garages, workshops, greenhouses, tents, shops, malls, shopping malls etc. However, heating devices should not be used in corrosive environments for aluminum, copper and steel as well as in highly dusty environments (above 0.3 g/m³). The devices should not be installed in rooms where they would be exposed to high humidity or direct contact with water.

2. DEVICE CHARACTERISTICS

2.1 CONSTRUCTION AND PRINCIPLE OF OPERATION

Casing: made of expanded polypropylene (EPP). This material is characterized by low density (light weighted) and high chemical and physical resistance. It has an excellent sound and thermal insulation properties. Moreover, material is environmentally friendly and "green", i.e. 100% recyclable.

Air stators: made of polypropylene PP. It is possible to adjust manually the air stators to achieve the needed direction of the air flow. There are also versions with confusor (increased airflow range) or with diffuser 360° (better mixing of supplied and room air).

Heating coil: made of copper and aluminum. Supplied by distribution medium (heating or cooling), which circulates through the coil and releases or extracts heat from the air. The coil has the following technical parameters: the maximum temperature of the heating factor is 120°C; maximum pressure 1.6 MPa; headers diameter ¾". Depending on dimensions of the device the heaters are equipped with 1, 2 or 3-row heating coils.

Axial blowing fan: impeller made of steel (400 mm) or PP (450 mm). The objective of the fan is to ensure air flow through the exchanger. It has a single-phase brushless EC motor characterized by high energy efficiency and wide range of speed control (voltage signal from 1.7 V to 10 V). Its parameters are following: IP44 or IP54 protection rating, rated current 1.5 or 2.95 A (depending on model). The models HC 20-EC, HC 30-EC, HC 35-EC and HC 45-EC have a fan with a diameter of 400 mm, and the HC 50-EC and HC 70-EC with a diameter of 450 mm.

Rotating mounting bracket (optional equipment): enables the device to be installed in several configurations (depending on the requirements) and the unit to be rotated in a horizontal plane.

2.2 DEVICE DIMENSIONS

- HC 20-3S, HC 30-3S, HC 35-3S and HC 45-3S:

- height (A): 598 mm
- width (B): 636 mm
- depth (C): 320 mm

- HC 50-3S, HC 70-3S and HC 80-3S:

- height (A): 698 mm
- width (B): 739 mm
- depth (C): 330 mm

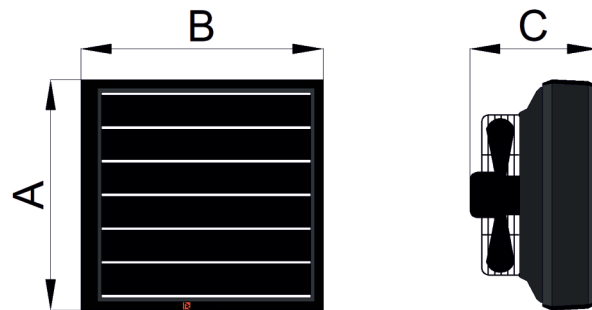

© 2022 Reventon Group sp. z o. o. [Ltd.]

2.3 DANE TECHNICZNE URZĄDZENIA

TECHNICAL DATA Product code	HC 20-EC	HC 30-EC	HC 35-EC	HC 45-EC	HC 50-EC	HC 70-EC
	WHHC20-EC-1985	WHHC30-EC-1986	WHHC35-EC-1987	WHHC45-EC-1988	WHHC50-EC-1989	WHHC70-EC-1990
Maximum heating capacity [kW]*	24.7	30.4	36.0	50.5	48.6	67.2
Heating capacity range [kW]**	1.91 – 32.7	2.28-40.3	2.80-47.6	4.54-66.7	4.36-64.1	5.93-88.9
Maximum airflow [m³/h]	4300	4100	3700	3400	4800	4000
Maximum horizontal range [m]	21	20.5	19.5	19	23	20
Number of rows [pcs.]	1	1	2	2	2	3
Capacity of water [dm³]	0.65	0.8	1.35	1.7	1.95	2.85
Maximum temperature of working fluid [°C]	120	120	120	120	120	120
Maximum working pressure [MPa]	1.6	1.6	1.6	1.6	1.6	1.6
Connection diameter ["]	3/4	3/4	3/4	3/4	3/4	3/4
Supply voltage [V] / Supply frequency [Hz]	230/50	230/50	230/50	230/50	230/50	230/50
Rated motor current [A]	1.5	1.5	1.5	1.5	2.95	2.95
Motor speed [rpm]	1600	1600	1600	1600	1400	1400
Motor power [W]	315	315	315	315	430	430
Protection degree IP [-]	44	44	44	44	54	54
Net weight [kg]	13.5	14	14.5	16	18	20
Noise [dB]***	60	59	58	58	59	58

* for water temp. 90/70°C, 0°C room temperature and 100% air expense

**min. heating capacity: 40/30°C, 20°C room temperature, 50% air expense // max. heating capacity 120/90°C, 0°C room temperature, 100% air expense

*** measurement at the distance 5 m from the device

Parameters	HC 20-EC 4300 m³/h				
Supply/return water temperature [°C]	120/90				
Dry bulb air inlet temperature [°C]	0	5	10	15	20
Heating capacity [kW]	32.7	30.7	28.7	26.8	24.9
Dry bulb air outlet temperature [°C]	21.3	25.3	29.3	33.2	37.2
Water flow [m³/h]	0.97	0.91	0.85	0.79	0.73
Pressure drop in the heat exchanger [kPa]	6	5	4	4	3

Parameters	HC 20-EC 4300 m³/h				
Supply/return water temperature [°C]	90/70				
Dry bulb air inlet temperature [°C]	0	5	10	15	20
Heating capacity [kW]	24.7	22.8	20.8	19.0	17.1
Dry bulb air outlet temperature [°C]	16.1	20.0	24.0	27.9	31.8
Water flow [m³/h]	1.09	1.00	0.92	0.84	0.75
Pressure drop in the heat exchanger [kPa]	7	6	5	5	4

Parameters	HC 20-EC 4300 m³/h				
Supply/return water temperature [°C]	80/60				
Dry bulb air inlet temperature [°C]	0	5	10	15	20
Heating capacity [kW]	20.8	18.9	17.0	15.2	13.4
Dry bulb air outlet temperature [°C]	13.5	17.5	21.4	25.3	29.2
Water flow [m³/h]	0.91	0.83	0.75	0.67	0.59
Pressure drop in the heat exchanger [kPa]	5	5	4	3	2

Parameters	HC 20-EC 4300 m³/h				
Supply/return water temperature [°C]	70/50				
Dry bulb air inlet temperature [°C]	0	5	10	15	20
Heating capacity [kW]	16.9	15.0	13.2	11.4	9.64
Dry bulb air outlet temperature [°C]	11.0	14.9	18.8	22.8	26.7
Water flow [m³/h]	0.74	0.66	0.58	0.50	0.42
Pressure drop in the heat exchanger [kPa]	4	3	2	2	1

Parameters	HC 20-EC 4300 m³/h				
Supply/return water temperature [°C]	50/30				
Dry bulb air inlet temperature [°C]	0	5	10	15	20
Heating capacity [kW]	9.07	7.32	5.65	4.01	2.45
Dry bulb air outlet temperature [°C]	5.9	9.8	13.8	17.7	21.7
Water flow [m³/h]	0.39	0.32	0.25	0.17	0.11
Pressure drop in the heat exchanger [kPa]	1	1	0	0	0

Parameters	HC 20-EC 4300 m³/h				
Supply/return water temperature [°C]	40/30				
Dry bulb air inlet temperature [°C]	0	5	10	15	20
Heating capacity [kW]	9.54	7.76	6.02	4.32	2.68
Dry bulb air outlet temperature [°C]	6.2	10.1	14.0	17.9	21.9
Water flow [m³/h]	0.83	0.67	0.52	0.37	0.23
Pressure drop in the heat exchanger [kPa]	5	3	2	1	0

Parameters	HC 30-EC 4100 m³/h				
Supply/return water temperature [°C]	120/90				
Dry bulb air inlet temperature [°C]	0	5	10	15	20
Heating capacity [kW]	40.3	37.8	35.4	32.9	30.6
Dry bulb air outlet temperature [°C]	27.4	31.1	34.8	38.4	42.1
Water flow [m³/h]	1.19	1.12	1.04	0.97	0.90
Pressure drop in the heat exchanger [kPa]	8	7	7	6	5

Parameters	HC 30-EC 4100 m³/h				
Supply/return water temperature [°C]	90/70				
Dry bulb air inlet temperature [°C]	0	5	10	15	20
Heating capacity [kW]	30.4	28.0	25.6	23.3	21.0
Dry bulb air outlet temperature [°C]	20.7	24.3	28.0	31.6	35.1
Water flow [m³/h]	1.34	1.23	1.13	1.03	0.92
Pressure drop in the heat exchanger [kPa]	11	9	8	7	5

Parameters	HC 30-EC 4100 m³/h				
Supply/return water temperature [°C]	80/60				
Dry bulb air inlet temperature [°C]	0	5	10	15	20
Heating capacity [kW]	25.6	23.2	20.9	18.6	16.4
Dry bulb air outlet temperature [°C]	17.4	21.0	24.7	28.2	31.8
Water flow [m³/h]	1.12	1.02	0.92	0.82	0.72
Pressure drop in the heat exchanger [kPa]	8	7	5	4	3

Parameters	HC 30-EC 4100 m³/h				
Supply/return water temperature [°C]	70/50				
Dry bulb air inlet temperature [°C]	0	5	10	15	20
Heating capacity [kW]	20.7	18.4	16.1	13.9	11.7
Dry bulb air outlet temperature [°C]	14.1	17.7	21.3	24.9	28.5
Water flow [m³/h]	0.91	0.80	0.71	0.61	0.51
Pressure drop in the heat exchanger [kPa]	5	3	3	3	2

Parameters	HC 30-EC 4100 m³/h				
Supply/return water temperature [°C]	50/30				
Dry bulb air inlet temperature [°C]	0	5	10	15	20
Heating capacity [kW]	11.0	8.88	6.81	4.80	2.89
Dry bulb air outlet temperature [°C]	7.5	11.1	14.8	18.4	22.1
Water flow [m³/h]	0.48	0.39	0.30	0.21	0.13
Pressure drop in the heat exchanger [kPa]	2	1	1	0	0

Parameters	HC 30-EC 4100 m³/h				
Supply/return water temperature [°C]	40/30				
Dry bulb air inlet temperature [°C]	0	5	10	15	20
Heating capacity [kW]	11.7	9.49	7.33	5.25	3.23
Dry bulb air outlet temperature [°C]	8.0	11.6	15.1	18.7	22.3
Water flow [m³/h]	1.01	0.82	0.64	0.45	0.28
Pressure drop in the heat exchanger [kPa]	7	5	3	2	1

Parameters	HC 35-EC 3700 m³/h				
Supply/return water temperature [°C]	120/90				
Dry bulb air inlet temperature [°C]	0	5	10	15	20
Heating capacity [kW]	47.6	34.8	41.9	39.1	36.3
Dry bulb air outlet temperature [°C]	36.0	39.3	42.6	45.8	49.0
Water flow [m³/h]	1.41	1.32	1.24	1.15	1.07
Pressure drop in the heat exchanger [kPa]	6	6	5	4	4

Parameters	HC 35-EC 3700 m³/h				
Supply/return water temperature [°C]	90/70				
Dry bulb air inlet temperature [°C]	0	5	10	15	20
Heating capacity [kW]	36.0	33.2	30.4	27.7	25.0
Dry bulb air outlet temperature [°C]	27.2	30.4	33.6	36.8	40.0
Water flow [m³/h]	1.59	1.46	1.34	1.22	1.10
Pressure drop in the heat exchanger [kPa]	8	7	6	5	4

Parameters	HC 35-EC 3700 m³/h				
Supply/return water temperature [°C]	80/60				
Dry bulb air inlet temperature [°C]	0	5	10	15	20
Heating capacity [kW]	30.4	27.7	24.9	22.3	19.7
Dry bulb air outlet temperature [°C]	23.0	26.2	29.4	32.6	35.7
Water flow [m³/h]	1.33	1.22	1.10	0.98	0.87
Pressure drop in the heat exchanger [kPa]	6	5	4	3	3

Parameters	HC 35-EC 3700 m³/h				
Supply/return water temperature [°C]	70/50				
Dry bulb air inlet temperature [°C]	0	5	10	15	20
Heating capacity [kW]	24.8	22.1	19.5	16.9	14.4
Dry bulb air outlet temperature [°C]	18.8	22.0	25.1	28.3	31.5
Water flow [m³/h]	1.09	0.97	0.85	0.74	0.63
Pressure drop in the heat exchanger [kPa]	4	3	3	2	1

Parameters	HC 35-EC 3700 m³/h				
Supply/return water temperature [°C]	50/30				
Dry bulb air inlet temperature [°C]	0	5	10	15	20
Heating capacity [kW]	13.6	11.1	8.62	6.21	3.88
Dry bulb air outlet temperature [°C]	10.3	13.5	16.7	19.9	23.1
Water flow [m³/h]	0.59	0.48	0.37	0.27	0.17
Pressure drop in the heat exchanger [kPa]	1	1	0	0	0

Parameters	HC 35-EC 3700 m³/h				
Supply/return water temperature [°C]	40/30				
Dry bulb air inlet temperature [°C]	0	5	10	15	20
Heating capacity [kW]	14.1	11.5	8.96	6.50	4.11
Dry bulb air outlet temperature [°C]	10.6	13.8	17.0	20.1	23.3
Water flow [m³/h]	1.22	1.00	0.78	0.56	0.36
Pressure drop in the heat exchanger [kPa]	5	4	2	1	0

Parameters	HC 45-EC 3400 m³/h				
Supply/return water temperature [°C]	120/90				
Dry bulb air inlet temperature [°C]	0	5	10	15	20
Heating capacity [kW]	66.7	62.8	59.0	55.3	51.6
Dry bulb air outlet temperature [°C]	55.6	58.0	60.5	62.9	65.2
Water flow [m³/h]	1.97	1.86	1.74	1.63	1.52
Pressure drop in the heat exchanger [kPa]	30	27	24	21	19

Parameters	HC 45-EC 3400 m³/h				
Supply/return water temperature [°C]	90/70				
Dry bulb air inlet temperature [°C]	0	5	10	15	20
Heating capacity [kW]	50.5	46.7	43.1	39.4	35.9
Dry bulb air outlet temperature [°C]	42.0	44.5	46.8	49.2	51.5
Water flow [m³/h]	2.22	2.06	1.9	1.74	1.58
Pressure drop in the heat exchanger [kPa]	39	33	29	25	14

Parameters	HC 45-EC 3400 m³/h				
Supply/return water temperature [°C]	80/60				
Dry bulb air inlet temperature [°C]	0	5	10	15	20
Heating capacity [kW]	43.4	39.7	36.1	32.5	29.0
Dry bulb air outlet temperature [°C]	36.1	38.5	40.9	43.2	45.5
Water flow [m³/h]	1.91	1.74	1.59	1.43	1.28
Pressure drop in the heat exchanger [kPa]	30	25	21	17	14

Parameters	HC 45-EC 3400 m³/h				
Supply/return water temperature [°C]	70/50				
Dry bulb air inlet temperature [°C]	0	5	10	15	20
Heating capacity [kW]	36.3	32.6	29.1	25.6	22.1
Dry bulb air outlet temperature [°C]	30.2	32.5	34.9	37.2	39.4
Water flow [m³/h]	1.59	1.43	1.27	1.2	0.97
Pressure drop in the heat exchanger [kPa]	22	18	15	11	9

Parameters	HC 45-EC 3400 m³/h				
Supply/return water temperature [°C]	50/30				
Dry bulb air inlet temperature [°C]	0	5	10	15	20
Heating capacity [kW]	21.9	18.3	14.9	11.4	8.01
Dry bulb air outlet temperature [°C]	18.2	20.5	22.7	24.9	27.0
Water flow [m³/h]	0.95	0.80	0.65	0.50	0.35
Pressure drop in the heat exchanger [kPa]	9	6	4	3	1

Parameters	HC 45-EC 3400 m³/h				
Supply/return water temperature [°C]	40/30				
Dry bulb air inlet temperature [°C]	0	5	10	15	20
Heating capacity [kW]	20.8	17.3	13.9	10.5	7.21
Dry bulb air outlet temperature [°C]	17.3	19.6	21.9	24.1	26.3
Water flow [m³/h]	1.80	1.50	1.20	0.91	0.62
Pressure drop in the heat exchanger [kPa]	29	21	14	9	4

Parameters	HC 50-EC 4800 m³/h				
Supply/return water temperature [°C]	120/90				
Dry bulb air inlet temperature [°C]	0	5	10	15	20
Heating capacity [kW]	64.1	60.4	56.7	53.1	49.5
Dry bulb air outlet temperature [°C]	37.8	41.1	44.4	47.7	50.9
Water flow [m³/h]	1.89	1.78	1.68	1.57	1.46
Pressure drop in the heat exchanger [kPa]	15	14	12	11	10

Parameters	HC 50-EC 4800 m³/h				
Supply/return water temperature [°C]	90/70				
Dry bulb air inlet temperature [°C]	0	5	10	15	20
Heating capacity [kW]	48.6	45.0	41.4	37.9	34.5
Dry bulb air outlet temperature [°C]	28.7	31.9	35.1	38.3	41.5
Water flow [m³/h]	2.14	1.98	1.83	1.67	1.52
Pressure drop in the heat exchanger [kPa]	20	17	15	13	11

Parameters	HC 50-EC 4800 m³/h				
Supply/return water temperature [°C]	80/60				
Dry bulb air inlet temperature [°C]	0	5	10	15	20
Heating capacity [kW]	41.7	38.1	34.7	31.2	27.8
Dry bulb air outlet temperature [°C]	24.6	27.8	31.0	34.2	37.3
Water flow [m³/h]	1.83	1.68	1.52	1.37	1.22
Pressure drop in the heat exchanger [kPa]	15	13	11	9	7

Parameters	HC 50-EC 4800 m ³ /h				
Supply/return water temperature [°C]	70/50				
Dry bulb air inlet temperature [°C]	0	5	10	15	20
Heating capacity [kW]	34.8	31.3	27.9	24.5	21.1
Dry bulb air outlet temperature [°C]	20.5	23.7	26.9	30.1	33.2
Water flow [m ³ /h]	1.52	1.37	1.22	1.07	0.92
Pressure drop in the heat exchanger [kPa]	11	9	7	6	4

Parameters	HC 50-EC 4800 m ³ /h				
Supply/return water temperature [°C]	50/30				
Dry bulb air inlet temperature [°C]	0	5	10	15	20
Heating capacity [kW]	20.9	17.5	14.2	10.9	7.55
Dry bulb air outlet temperature [°C]	12.3	15.5	18.6	21.7	24.7
Water flow [m ³ /h]	0.91	0.76	0.61	0.47	0.33
Pressure drop in the heat exchanger [kPa]	4	3	2	1	1

Parameters	HC 50-EC 4800 m ³ /h				
Supply/return water temperature [°C]	40/30				
Dry bulb air inlet temperature [°C]	0	5	10	15	20
Heating capacity [kW]	20.0	16.6	13.3	10.1	6.86
Dry bulb air outlet temperature [°C]	11.8	14.9	18.1	21.2	24.3
Water flow [m ³ /h]	1.73	1.44	1.15	0.87	0.59
Pressure drop in the heat exchanger [kPa]	15	11	7	4	2

Parameters	HC 70-EC 4000 m ³ /h				
Supply/return water temperature [°C]	120/90				
Dry bulb air inlet temperature [°C]	0	5	10	15	20
Heating capacity [kW]	88.9	83.7	78.7	73.7	68.7
Dry bulb air outlet temperature [°C]	62.1	64.3	66.5	68.5	70.6
Water flow [m ³ /h]	2.63	2.47	2.32	2.18	2.03
Pressure drop in the heat exchanger [kPa]	21	19	17	15	13

Parameters	HC 70-EC 4000 m ³ /h				
Supply/return water temperature [°C]	90/70				
Dry bulb air inlet temperature [°C]	0	5	10	15	20
Heating capacity [kW]	67.2	62.3	57.4	52.5	47.9
Dry bulb air outlet temperature [°C]	47.0	49.1	51.2	53.2	55.2
Water flow [m ³ /h]	2.96	2.74	2.53	2.32	2.11
Pressure drop in the heat exchanger [kPa]	28	24	21	17	15

Parameters	HC 70-EC 4000 m ³ /h				
Supply/return water temperature [°C]	80/60				
Dry bulb air inlet temperature [°C]	0	5	10	15	20
Heating capacity [kW]	57.9	53.0	48.2	43.5	38.8
Dry bulb air outlet temperature [°C]	40.5	42.5	44.6	46.6	48.6
Water flow [m ³ /h]	2.54	2.33	2.12	1.91	1.71
Pressure drop in the heat exchanger [kPa]	21	18	15	12	10

Parameters	HC 70-EC 4000 m ³ /h				
Supply/return water temperature [°C]	70/50				
Dry bulb air inlet temperature [°C]	0	5	10	15	20
Heating capacity [kW]	48.5	43.7	38.9	34.3	29.7
Dry bulb air outlet temperature [°C]	33.9	35.9	37.9	39.9	41.8
Water flow [m ³ /h]	2.12	1.91	1.70	1.50	1.30
Pressure drop in the heat exchanger [kPa]	15	13	10	8	6

Parameters	HC 70-EC 4000 m ³ /h				
Supply/return water temperature [°C]	50/30				
Dry bulb air inlet temperature [°C]	0	5	10	15	20
Heating capacity [kW]	29.4	24.8	20.2	15.6	11.0
Dry bulb air outlet temperature [°C]	20.6	22.5	24.5	26.3	28.1
Water flow [m ³ /h]	1.28	1.07	0.88	0.68	0.48
Pressure drop in the heat exchanger [kPa]	6	4	3	2	1

Parameters	HC 70-EC 4000 m ³ /h				
Supply/return water temperature [°C]	40/30				
Dry bulb air inlet temperature [°C]	0	5	10	15	20
Heating capacity [kW]	27.8	23.2	18.6	14.2	9.76
Dry bulb air outlet temperature [°C]	29.4	21.4	23.4	25.3	27.2
Water flow [m ³ /h]	2.41	2.01	1.62	1.23	0.85
Pressure drop in the heat exchanger [kPa]	20	15	10	6	3

3. ASSEMBLY

3.1. GENERAL PRINCIPLES

During installation, ensure a free air flow to the device and do not restrict the air stream supply. The figures below show the recommended distances between the heater and building partitions:

a) in case of wall mounting

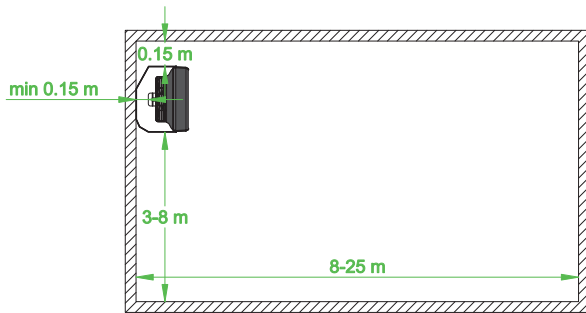

b) in case of ceiling mounting

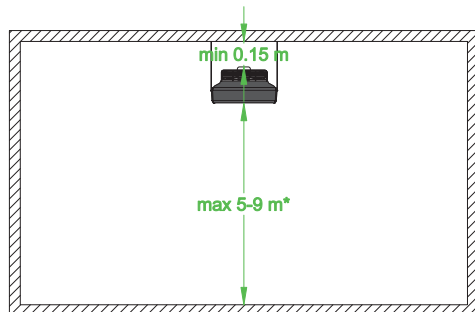

* the maximum vertical range depends on the model

In case of higher heat demand, more units can be installed in the room. In order to ensure proper air flow, it is necessary to maintain the recommended distances between the heaters, as shown in the following figure.

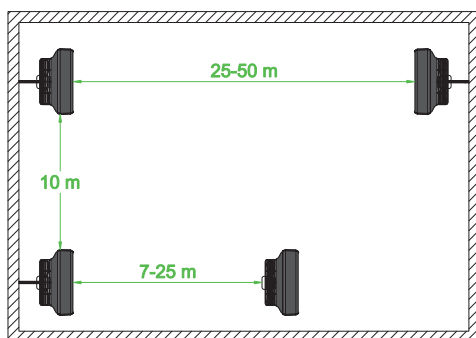

3.2. ROTATING MOUNTING BRACKET

The Reventon Group HC series devices can be assembled using a rotating mounting bracket. It enables the heaters installation on the wall or ceiling, depending on the required optimal direction of airflow.

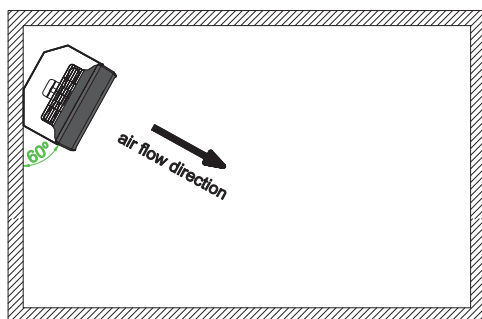

4. INSTALLATION INSTRUCTIONS

4.1. CONNECTION OF THE DEVICE TO THE HYDAULIC SYSTEM

- pipes should be connected as indicated on the heater (supply from below, return from above)

- connecting the device to the hydraulic installation, do remember to hold the connectors by pipes spanner

Not keeping to the recommendation may cause the damages of the heating coil.

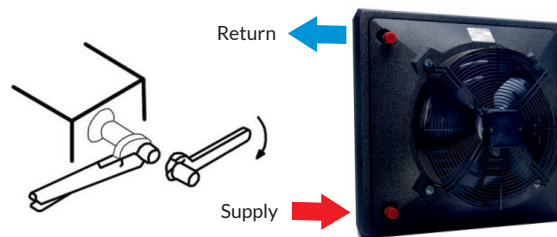

- it is recommended to use filter on the water supply pipe

- it is recommended to use the following valves:

- vent valve in the highest place on the hydraulic installation
- cut off valve on the supply and return pipes of the device

- installation has to be secured against excessive increase of pressure

- it is recommended to check the leak tightness of the hydraulic system before plugging the electric supply

4.2. CONNECTION OF THE DEVICE TO THE ELECTRICAL SYSTEM

- all works concerning electrical installation should be made by the qualified personnel (who possess required authorizations to install electrical equipment), based on wiring schematic diagrams (see 7)

- the electrical installation of the building shall have a residual current device

- it is recommended to check the electric installation and controls before the first start

5. PRECAUTIONS & WARNINGS

The precautions mentioned below must be strictly followed during operation of the device:

- all works concerning electrical installation (disassembly, repair etc.) should be made by the qualified staff, who possess the qualifications due to the domestic and local norms, regarding electrical installations

- EC motor starts if voltage signal is at least 1.7 V - despite this for lower values of voltage the fan still remains under voltage

- before service or exchange of the device it is obligatory to cut off the current supply

- do not limit or cover the inlet and outlet of the device

- do not install, service the device with wet hands or barefoot

- the device should be kept out of reach of children and animals

- the device does not consist of the anti-frost protection - the temperature in the room, where device is installed, should not go below 0°C; if such situation could take place empty the device out of water

- after the turn off, the elements of device may be warm

- after operating time of the device, please utilize it concerning the local norms and regulations

- it is recommended to clean the device periodically (at least twice a year):

- heating coil blow with compressed air
- fan casing and blades clean from dirt

- failure to comply with cleaning obligations may have a negative effect on technical parameters of the device and lead to loss of warranty

- if the device is not used for a longer time disconnect the power supply

- air stators of the device have to be open in at least 30% before first start:

- **standard version** - opening of air stators must be done by two hands in parallel



- **version with diffuser 360°** - air stators of diffuser 360° must be done by two hands to the outside

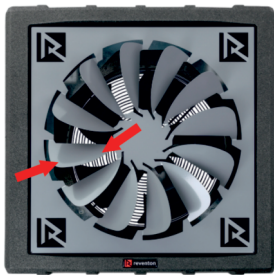

- **version with confusor** - the outlet do not have air stators which must be open

- using diffuser 360° or confusor causes decrease of device airflow of around 10% and consequently reduction of its heating capacity of about 5%

6. CONTROLS

Usage of automatic control dedicated to the air water heaters of Reventon Group gives great possibilities of adjusting the efficiency of the heater in different, depending on needs, degree of its operation automation. We can offer the following:

Potentiometer EC

enables to control EC motors by 0-10 V control signal. A convenient knob is used for this, allowing in practice to adjust the fan efficiency in the range of 0-100%. The potentiometer also has an additional switching contact which cuts off the voltage from the fans when there is no need to work.



Output signal: 0 - 10 V
 Power supply: 10 - 12 V DC / 1mA
 Impedance: 10 kΩ + - 20%
 Maximum load of the switching contact:
 3 A / 230 V AC or 3 A / 12 V DC
 Weight: 0.35 kg
 Degree of protection: IP 54

Programmable controller HMI EC

is used to regulate equipped with EC motors. It is an advanced controller with many functions i. a. operation in heating, cooling or mixed mode, programmable mode, valve control, automatic selection of the fan speed. Together with the controller an external sensor is provided, which allows to read the temperature in the required place, even remote from the controller. In addition, the device can be integrated with the BMS building control system (using the MODBUS communication protocol).



Voltage/ Frequency: 230 V AC / 50 - 60 Hz
 Maximum current: 5 A
 Operating temperature range: 0 - 45°C
 Regulation range: 5°C - 35°C
 Regulation accuracy: ± 0.5°C
 External temperature sensor: NTC 10K
 Communication: RS485
 Dimensions: 86 x 86 x 13.3 mm
 Weight: 270 g
 Degree of protection (housing): IP 20
 Degree of protection (external sensor): IP 68

Two-way valve with actuator 3/4"

is used to automatically regulate the flow of the heating medium.



Voltage / Frequency: 230 V AC / 50 - 60 Hz
 Power consumption: 2 VA
 Kvs coefficient: 6.3 m³/h
 Stroke: 3 mm
 Operating condition of actuator: -5°C - 60°C
 Running time: 3 - 5 min
 Degree of protection: IP 54

Three-way valve with actuator HC 3/4"

is used to automatically regulate the flow of the heating medium.



Power supply/ Frequency: 230 V AC / 50 - 60 Hz
 Power consumption: 7 VA
 Kvs coefficient: 6.5 m³/h
 Operating condition of actuator: 0 - 60°C
 Running time (motor): 18 s
 Running time (return spring): 5 s
 Degree of protection: IP 20

Relay Module RM-16A

allows to connect a receiver with higher current consumption than permissible current load of connected regulator.



Power supply/ Frequency : 230 V AC / 50 - 60 Hz
 Maximum rated current: 16 A
 Input: NO/COM
 Input: SL Connection of a regulator with the voltage relay 230 V
 Dimension: 47 x 47 x 20 mm

Manual thermostat HC

controls operation of the heater. Switches the unit off automatically when the set temperature is reached.



Power supply/ Frequency: 230 V AC / 50 - 60 Hz
 Maximum rated current: 3 A
 Operating temperature: 0 - 40°C
 Temperature control range: 10 - 30°C
 Control accuracy: < 1°C
 Degree of casing's protection: IP 30

7. CONNECTION SCHEMES

7.1 SCHEMES FOR HC20-EC, HC30-EC, HC35-EC, HC45-EC

LEGEND:

1. Power
2. Main switch, overcurrent circuit breaker*
3. Air water heater HC-EC
4. Potentiometr EC
5. Programmable controller HMI EC
6. Valve with actuator HC 3/4"
7. External temperature sensor

* main switch and safety fuses are not included in the set

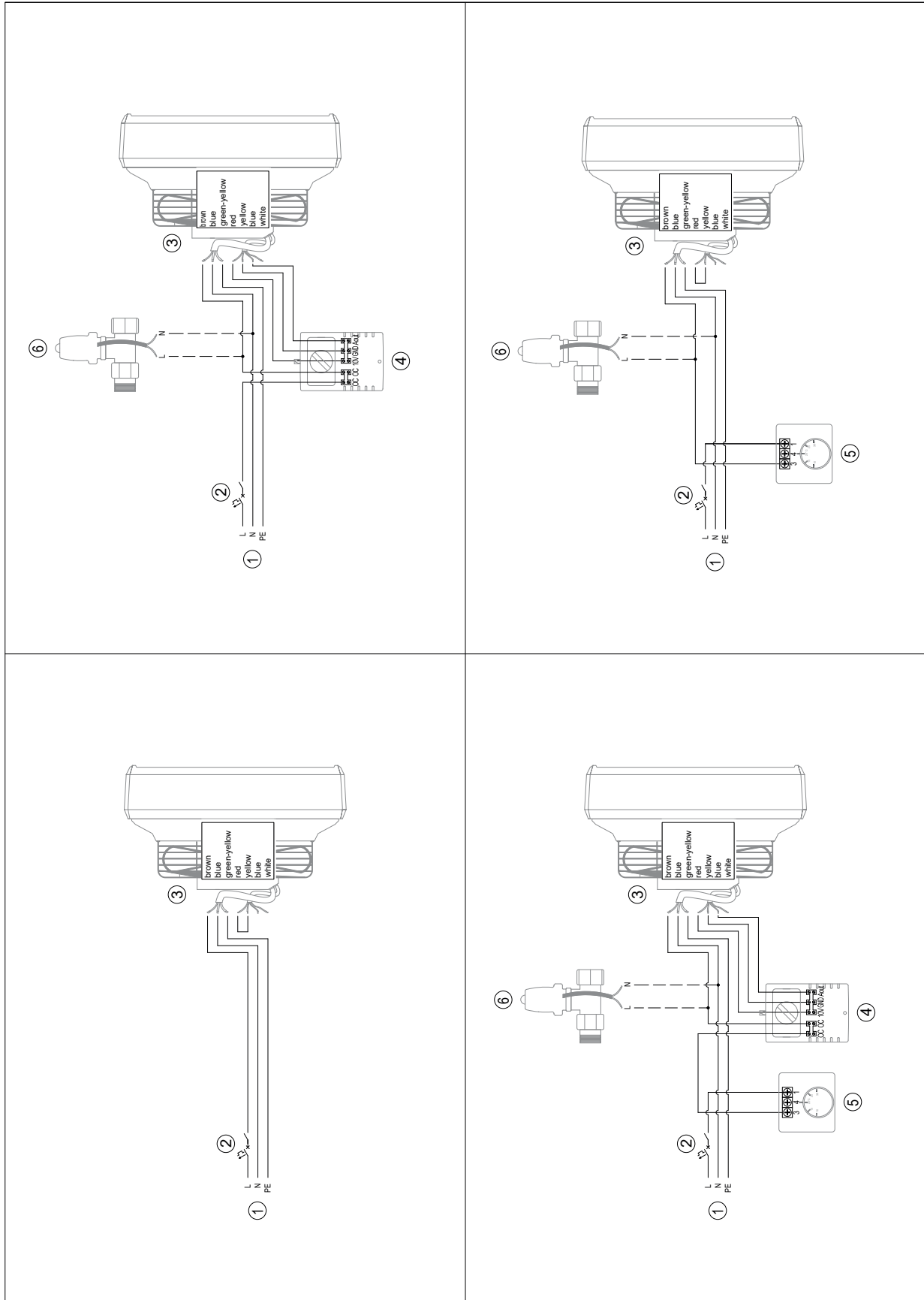

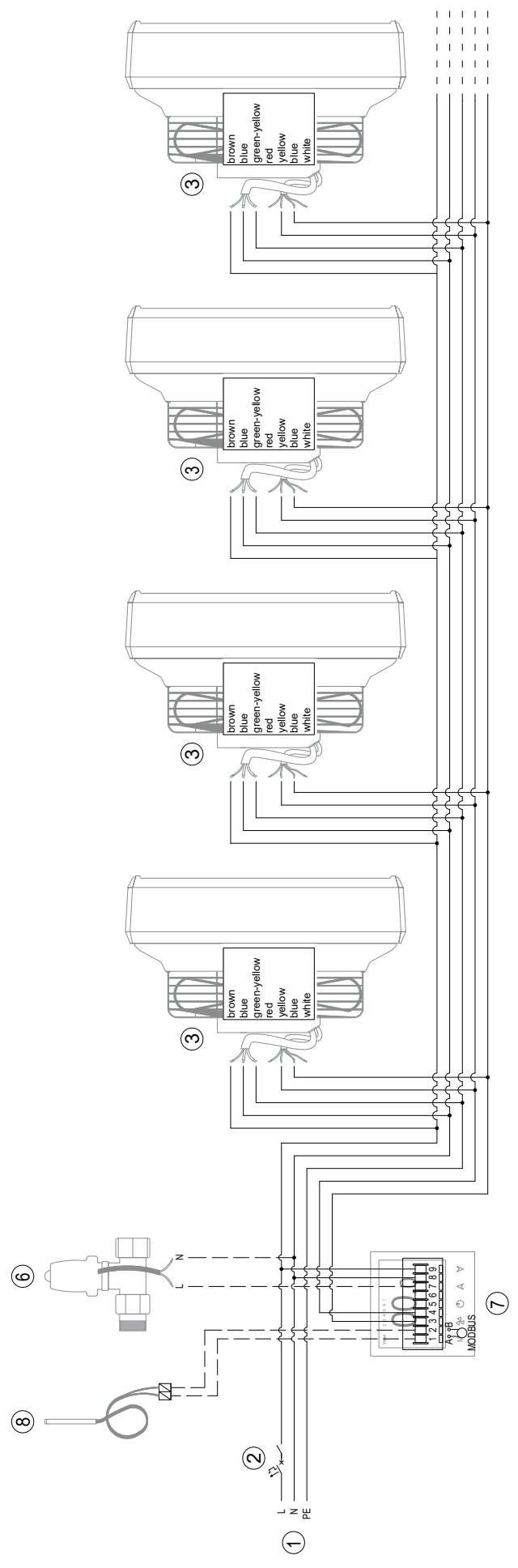
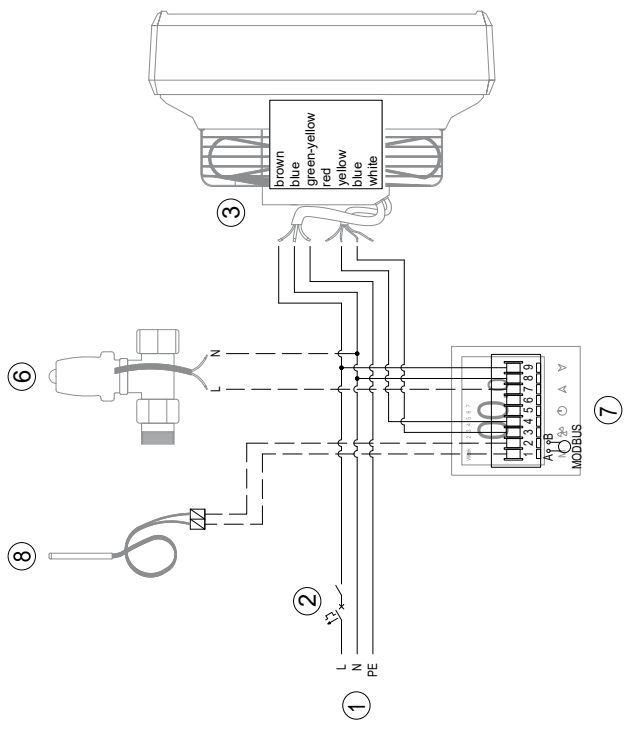

7.2 SCHEMES FOR HC50-EC, HC70-EC

LEGEND:

1. Power
2. Main switch, overcurrent circuit breaker*
3. Air water heater HC-EC
4. Potentiometr EC
5. Programmable controller HMI EC
6. Valve with actuator HC 3/4"
7. External temperature sensor

* main switch and safety fuses are not included in the set

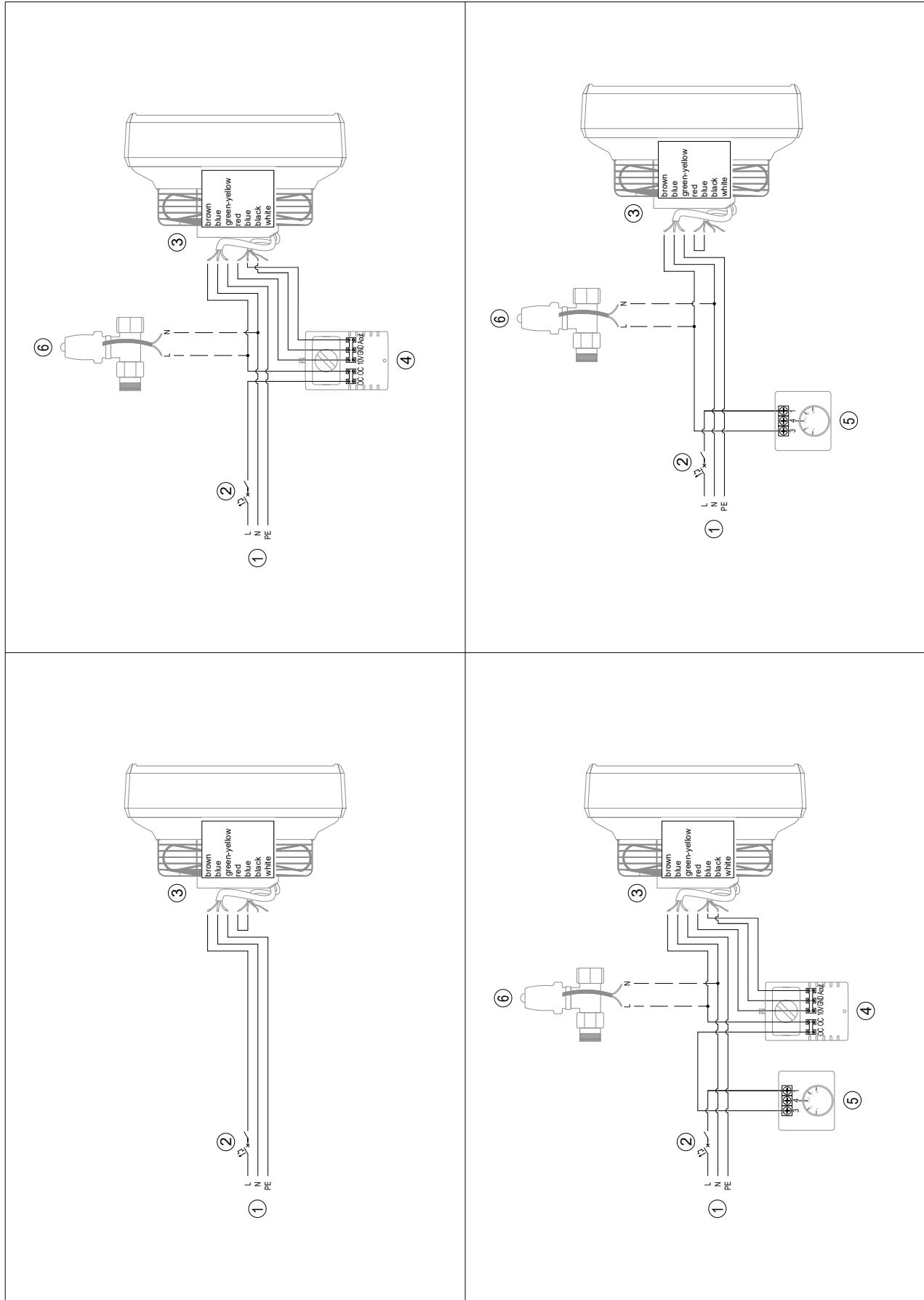

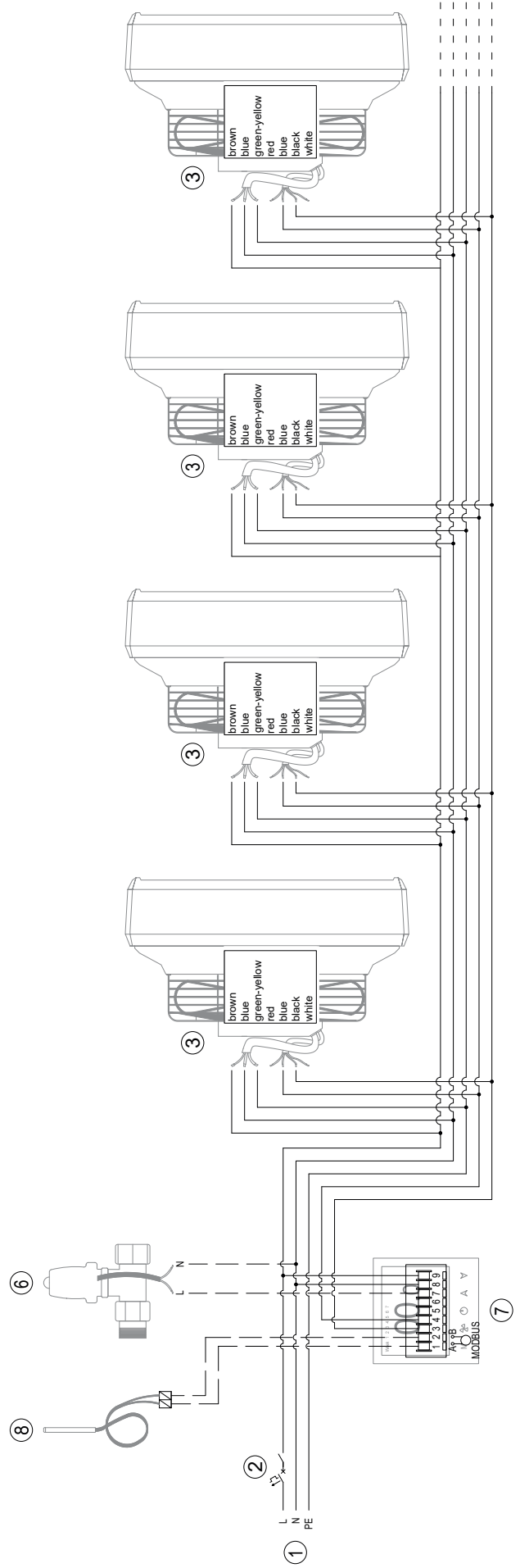
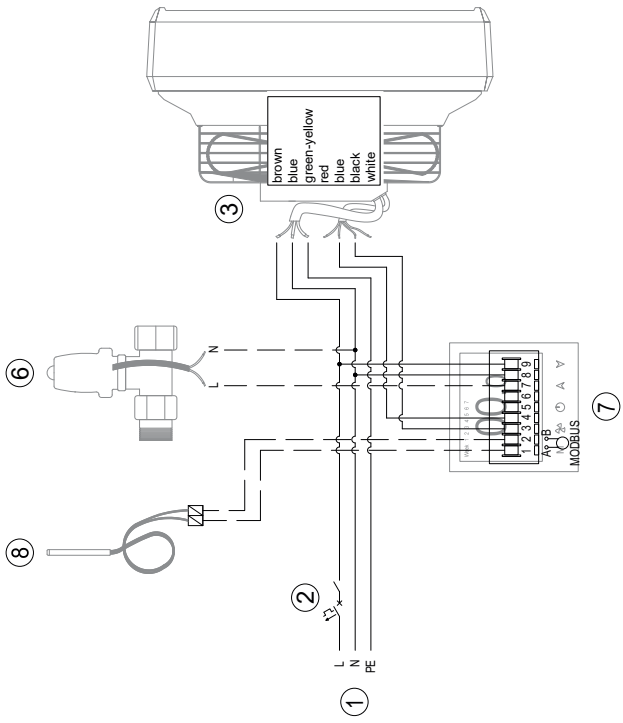

8. TERMS OF WARRANTY

I. The company Reventon Group Sp. z o. o. [Ltd.], hereinafter referred to as the guarantor, provides 24-month warranty protection period for the following devices:

- air water heater HC 20-EC
- air water heater HC 30-EC
- air water heater HC 35-EC
- air water heater HC 45-EC
- air water heater HC 50-EC
- air water heater HC 70-EC

II. The warranty protection is valid from the purchasing date by end user (i.e. the issue date of invoice) but not longer than 30 months from leaving the warehouse of Reventon Group Sp. z o. o. [Ltd.].

III. The warranty claim should be reported via the complaint form on the website (<https://reventongroup.eu/en/complaints>). The scan or the photo of the fulfilled Warranty Card and the purchase invoice must be attached to the form. The Warranty Card is not required in case of accessories.

IV. The guarantor is committed to consider the claim within 14 working days since the date of reporting (i. e. the day of receipt of the correctly fulfilled warranty form).

V. In exceptional cases, the guarantor reserves the right to extend the time for consideration of the request, especially if the defect is not permanent one and its determination requires a deeper analysis. The extension must be notified by the guarantor before the end of the 14th working day.

VI. Under the warranty, the guarantor provides a repairment, replacement (the device or its component) or refund for the defective item within a specified time.

VII. In the case of replacement of a device component, the warranty protection of the whole unit is not prolonged.

VIII. The guarantor does not cover the costs of disassembly and eventual reassembly of the complaint device.

IX. The guarantor may decide to bring the defective device or its component to the service of Reventon Group Sp. z o. o. [Ltd.]. In such case the transport of the item is organised and paid by the guarantor. The responsibility of the device's owner is to prepare the item for the shipment - the device must be packed in a way which protects it against transport damages and the dimensions and weight of the package must not exceed 660 x 650 x 400 mm and 30 kg respectively. In the case of elements which cannot be packed in this way, the method of shipment must be agreed and approved by Reventon Group Sp. z o. o. [Ltd.]. In the case of sending a non-standard package without agreement of the service of Reventon Group Sp. z o. o. [Ltd.], the guarantor reserves the right to charge the owner of device with all additional transport costs.

X. In the case of arrival of the authorized service of the guarantor or an installer to fix the complaint item, the customer must ensure them seamless access to the device and all required media like electricity, water, lighting etc. free of charge.

XI. The warranty protection does not cover the parts of the device subject to the normal usage and the following cases:

- a) mechanical damage of the product
- b) defects and damages through:
 - improper storage or transport
 - improper or non-compliant use and maintenance (i. e. inconsistent with the manual)
 - using the device in the improper conditions (too high humidity, too high or too low temperature, impact of the surrounding, sun etc.)
 - unauthorized (i. e. by the user or other unauthorized persons) repairs, modifications or construction changes
 - connecting equipment inconsistent with the technical documentation
 - connecting additional equipment, which is not recommended by the guarantor
 - improper power supply
 - random events (like fire, flood, storm etc.)
- c) elements which wear and tear such as discolour of the housing

If there is any of the above, the claimant will be charged for transport and /or repairs.

XII. During collection of the device, the item must be checked exactly by the receiver to exclude transport damages. If any of them is observed, the damage report in presence of the product deliverer have to be filled - such report is the basement for the warranty claim. The damage report must be provided by the product deliverer.

XIII. The guarantor does not take the responsibility for potential losses and damages related to the downtime of the device during its failure and the complaint considering time.

XIV. Any changes in the Warranty Terms, improper use of the product as well as traces of self repairing (beyond the guarantor service) or alterations cause, the warranty become invalid.

XV. These Warranty Terms do not exclude or limit any rights arising from the pledge.

XVI. Not following to any of the warranty regulations makes the protection invalid.

XVII. All correspondence should be sent to the following address: Reventon Group Sp. z o. o. [Ltd.], 556 Wyzwolenia Street, 43 340 Kozy, Poland or email address: serwis@reventongroup.eu

Warranty Card

1 - Model and serial number* or product code	2 - Address and place of assembly
3 - Date of connection to:	4 - Stamp and signature of installer:
Heating/cooling installation (if applicable)	
Ventilation installation (if applicable)	
Electrical installation (if applicable)	

* serial number is required only for water heaters HC-3S, HC-EC and FARMER HCF series and recovery units INSPIRO, INSPIRO BASIC and VERTIC series



reventon
INDUSTRIAL SOLUTIONS

Reventon Group Sp. z o.o. [Ltd.], 556 Wyzwolenia Street, 43-340 Kozy, Poland, www.reventongroup.eu